

HL122 SERIES

Multi-purpose digital platform scales.

by **Avery Weigh-Tronix**

DESCRIPTION

The HL122 light industrial scale offers three-in-one flexibility. Weighing, counting or checkweighing, this low cost, high performance machine is the ideal choice for a wide range of weighing applications.

Piece weights are easily selected and count quantities clearly displayed. Optional transmission of totals to a PC or a 24-character tally roll printer is available.

A variety of features are available to assist with checkweighing routines including selectable targets by weight or by the number of pieces and programmable under and overweight tolerances.

The display instantly confirms "under", "accept" and "over" weights and a scale programmable, audible alarm warns the operator of any potential problems. An optional relay output is available for monitoring weight tolerances.

An addition function is available to store the number of weighings or pieces and their accumulated total. This information can be optionally relayed to a PC or printer.



HIGHLIGHTS

- Low cost, high performance
- For weighing, counting or checkweighing
- Large, easy to read display
- Battery or mains operation
- Backed by a nationwide service network

DIMENSIONS

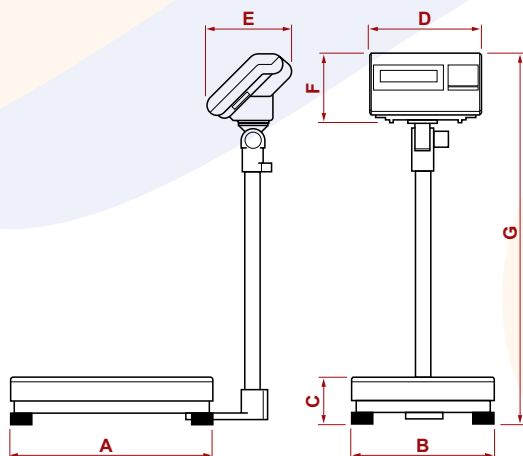

370mm x 520mm Platform

A = 520 mm

B = 370 mm

C = 127 mm

460mm x 600mm Platform

A = 600 mm

B = 460 mm

C = 160 mm

INDICATOR

D = 278 mm

E = 204 mm

F = 174 mm

G = 930 mm