

SK-WP SERIES

Water-proof bench scale.

by **A&D**
A&D MERCURY PTY LTD

FEATURES

- Trade Approved (NMI No. 6/4D/216) (Excludes SK-5001WP)
- Washable: Dust and Water-Proof (IP-65)
- Stainless Steel Body and Weighing Pan
- 1/2000 Resolution (SK-5001WP: 1/5000)
- Large and Clear LCD Display (25mm)
- Large Square Weighing Pan
- Designed to meet Trade Measurements Regulations
- Portable (6 D-Type Batteries, Batteries not included)
- Net Weight / Stability Indication
- Low Battery Indication
- Separate Keys for Power and Re-Zero
- Auto Power Off
- AC Adapter (Supplied as Standard)



MODELS

Model	Capacity & Division
SK-1000WP	1000g x 0.5g
SK-2000WP	2000g x 1g
SK-5000WP	5000g x 2g
SK-5001WP	5000g x 1g*
SK-10KWP	10kg x 5g
SK-20KWP	20kg x 10g

* SK-5001WP Not Trade-Approved

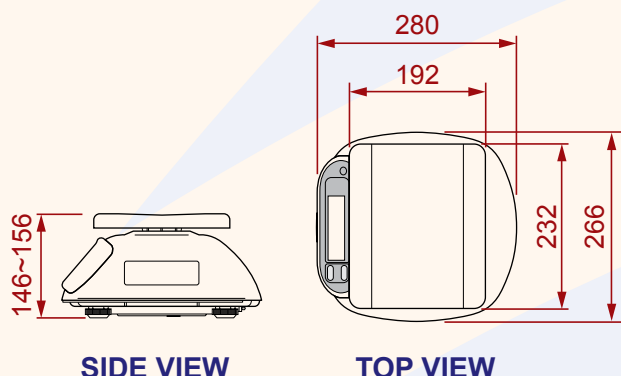

SPECIFICATIONS

MODEL	SK-1000WP	SK-2000WP	SK-5000WP	SK-5001WP	SK-10KWP	SK-20KWP
Capacity/Divisions	1000 x 0.5g	2000 x 1g	5000 x 2g	5000 x 1g	10kg x 5g	20kg x 10g
Linearity	±1g	±2g	±5g	±2g	±10g	±20g
Repeatability	0.5g	1g	2g	1g	5g	10g
Display	Liquid Crystal Display, 25mm High Digits					
Pan Size	232mm (W) x 192mm (D)					
Battery Life Approx.	600 hours with manganese type batteries 1200 hours with alkaline type batteries					
Operating Temp.	-10°C to +40°C					
Weight	2.9kg				1.9kg	
Calibration Mass	1000g	2000g	5000g	5000g	10kg	20kg
Power	6 x "D" size batteries or AC adaptor (optional)					